



Sheer
Driving Pleasure



THE NEW BMW M5.



THE NEW BMW M5.



inspired by **BMW Individual**

DIGITAL DISCOVERY: THE NEW BMW BROCHURES APP.



More information, more driving pleasure: The new BMW brochures app offers you a brand new digital and interactive BMW experience. Download the BMW brochures app for your smartphone or tablet now and explore new perspectives of your BMW.

INNOVATION AND TECHNOLOGY.



18 M powertrain and M suspension



22 Driver assistance and safety



24 Connectivity and infotainment.

EQUIPMENT.



26 BMW M5



28 BMW M5 First Edition



30 BMW Individual



32 Equipment highlights



38 Exterior colours



40 Interior colours

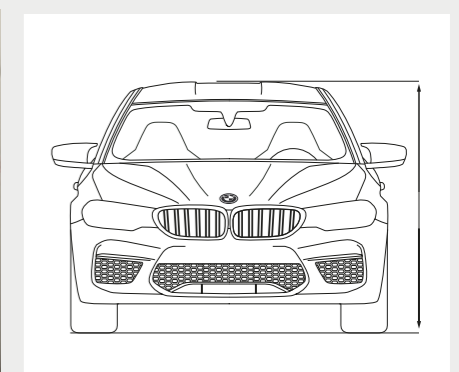

42 Technical data



FORMULA M.



WELCOME TO THE WORLD OF HIGH TECH.

ALL BMW 5 SERIES DRIVER ASSISTANCE SYSTEMS, INCL. DRIVING ASSISTANT PLUS^{1,2} /// M-SPECIFIC HEAD-UP DISPLAY³ /// M SERVOTRONIC FOR DIRECT AND PRECISE STEERING /// NEW GEAR SELECTOR WITH DRIVELOGIC SWITCH



¹ Available as optional equipment.

² This function can be limited by darkness and fog.

³ The visuals in the BMW Head-Up Display are not fully visible when viewed through polarised sunglasses. Functionality shown is dependent on equipment. Further optional equipment is required for the display.



BOUNDLESS DRIVING PLEASURE.

M TWIN POWER TURBO 8-CYLINDER PETROL ENGINE WITH 750 NM AND 441 KW (600 HP) /// M xDRIVE WITH ACTIVE M DIFFERENTIAL /// 8-SPEED M STEPTRONIC TRANSMISSION WITH DRIVELOGIC /// LOWER WEIGHT THANKS TO INTELLIGENT LIGHTWEIGHT CONSTRUCTION



**PACKED WITH POWER
UP TO THE
CARBON ROOF.**

CARBON ROOF AND M5 BONNET WITH SCULPTED
CONTOURS /// AERODYNAMICALLY SHAPED M WING
MIRRORS /// WIDENED BODY WITH M-SPECIFIC GILLS



LIFE IN THE FAST LANE.

SPECIFIC M REAR DIFFUSER ///
M REAR SPOILER /// FOUR TYPICAL
M TAILPIPES WITH CHROME TRIM



RESERVE YOUR SPOT AT THE TOP.

FULLY ELECTRIC M MULTIFUNCTION SEATS*
WITH FULL MERINO LEATHER UPHOLSTERY* AND
ILLUMINATED M5 BADGE IN THE HEADRESTS ///
M LEATHER STEERING WHEEL WITH SHIFT
PADDLES AND M1/M2 BUTTONS

* Available as optional equipment.



inspired by **BMW Individual**

A CAR THAT'S GOT IT ALL. EXCEPT FOR COMPETITION.

SPORTS CAR OR EXECUTIVE SALOON? BOTH, ACTUALLY. WHEN ULTIMATE POWER IS PRESENTED WITH SUCH STYLE, THE ASSURED OUTCOME IS VICTORY. AT 441 KW (600 HP) THE NEW BMW M5 IS MORE POWERFUL THAN EVER, WITH ITS EVERYDAY USABILITY UNDIMINISHED. EQUIPPED FOR THE FIRST TIME WITH M xDRIVE, ITS DYNAMIC PERFORMANCE, AGILITY AND TRACTION ARE ENHANCED EVEN FURTHER – FOR A NEW LEVEL OF DRIVING PLEASURE. ONLY WHEN NOTHING CAN BE ADDED OR TAKEN AWAY CAN THE RESULT BE CONSIDERED THE ULTIMATE DRIVING MACHINE WORTHY OF THE LETTER M. GET IN, START THE ENGINE AND EXPERIENCE THE NEXT LEVEL OF EXHILARATION. **WELCOME TO THE NEW BMW M5 SALOON.**





A passion for motor racing, driven by perfection: BMW M automobiles provide a level of dynamic performance, precision and power that meets the highest requirements. The M TwinPower Turbo engines aren't standard engines tuned for higher power output, but specially developed powerplants that bring motorsport technology to the road. All other components are likewise perfectly tailored to the overall concept. Everything from the suspension to the transmission, steering and brakes is designed for one purpose only: to deliver maximum performance, whatever the challenge.

M TwinPower Turbo 8-cylinder petrol engine

- Max. output: 441 kW (600 hp)
- Max. torque: 750 Nm
- Acceleration 0–100 km/h: 3.4 s
- Top speed: 250 km / 305 km/h with M Driver's package¹
- Combined fuel consumption: 10.5 l/100 km
- Combined CO₂ emissions: 241 g/km

The **M sports exhaust system**¹ delivers a dynamic sound that can be modified via the integrated exhaust valve mechanism. The SPORT and SPORT+ programmes, which can be selected via the Driving dynamics buttons, are accentuated by an even more intense engine sound, while the comfort-oriented programme prioritises more discreet engine acoustics.

The **M sound control** buttons in the centre console allow the athletic engine sound and robust tailpipe noise to be adjusted inside the vehicle. Depending on the driver's preference, the engine's linear power development and tremendous thrust can be showcased in their best light, or the noise level can be discreetly subdued.



The **M xDrive with Active M differential** guarantees maximum traction and dynamic performance, both in everyday driving and on the racetrack. With DSC switched off, the driver can choose between the drive settings 4WD, 4WD Sport and 2WD, depending on personal preference and road conditions.



In **4WD mode**, the M xDrive has a set-up focused on optimum control and superior traction. This is particularly useful when road conditions are poor. At the same time, this mode enables drivers to explore the dynamic potential of the new BMW M5 with the stability control system switched off.

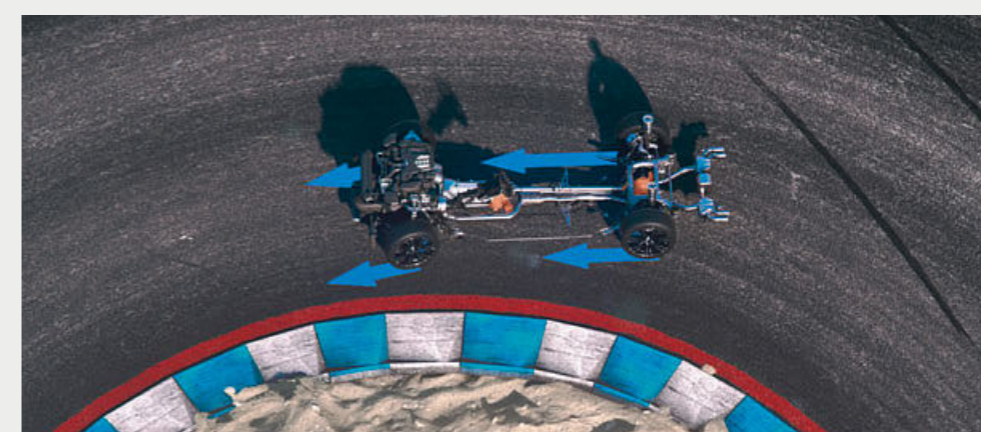

In **4WD Sport mode**, the M xDrive set-up is adjusted for increased agility and sporting ability. The combination of absolute precision, effortless handling and convincing traction ensures maximum driving enjoyment – especially on a race track.

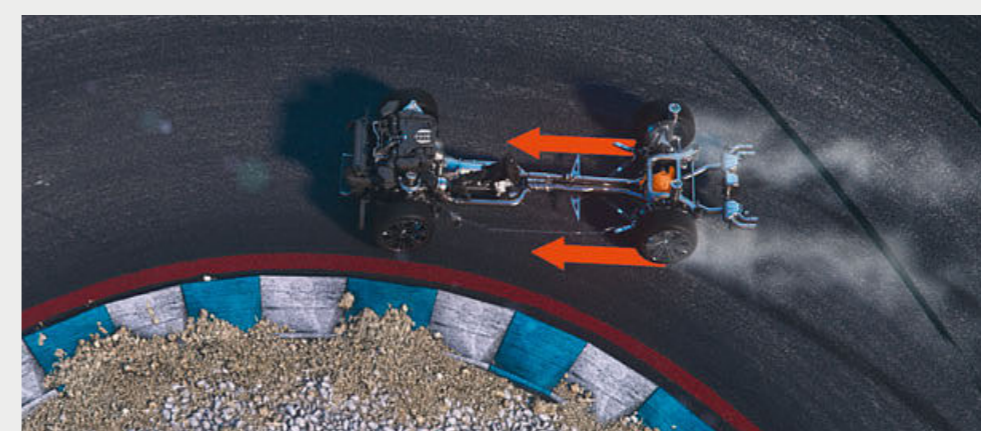

In **2WD mode**, the new BMW M5 enables driving enthusiasts to savour the purist enjoyment of a rear-wheel drive high-performance saloon, with the Active M differential ensuring supremely agile handling and outstandingly precise control.

¹ Available as optional equipment.

Further information on fuel consumption and CO₂ emissions can be found in technical data or consult your local BMW partner.



Every BMW M development project begins with one aim: delivering outstanding dynamic ability. Every single component within the M5 suspension is designed for maximum performance, to ensure optimal road contact even when pushing the car to its limits. Aerodynamics optimisation, lightweight construction and other BMW M technologies raise the vehicle's level of performance even further.

M5 suspension.

The fundamentally revised M5 suspension fully highlights the vehicle's enormous dynamic potential. The vehicle features a wider front track, adjusted springs and harder stabilisers as well as a unique calibration of the Variable Damper Control, all of which work together to provide a distinctly athletic driving style.

The **M Carbon ceramic brake**^{1,2} delivers braking power more directly. It is non-corrosive, very resistant to abrasion, tolerates more heat and contributes to a lower vehicle weight, which has a positive impact on agility, dynamics and acceleration. Matt Gold-coloured brake callipers with the M designation make this special technical equipment visible from outside the car.



User-configured M1 and M2 set-ups enable drivers to save individual driving dynamics settings.

The new BMW M5 is able to save two individual driving dynamics configurations. Saving a set-up is easy and intuitive: to save the current setting, drivers simply have to press and hold down the M1 or M2 button on the steering wheel; alternatively, they can configure a set-up via the BMW iDrive menu. The M1/M2 buttons on the steering wheel are also used to access a saved set-up. The selected mode – M1 or M2 – is displayed in the instrument cluster.

Configuration options.

M xDrive: new for the BMW M5, with 4WD, 4WD Sport and 2WD modes
 8-speed M Steptronic transmission with Drivelogic: shift mode (D or S) and shift programs (level 1, 2 and 3)
 M TwinPower Turbo engine: response – Efficient, Sport or Sport+
 M Servotronic: servo boost – COMFORT, SPORT or SPORT+
 M suspension: response – COMFORT, SPORT or SPORT+
 Dynamic Stability Control (DSC): modes – DSC ON, MDM (M Dynamic Mode) or DSC OFF
 Drivers can also adjust the display mode of the BMW M-specific Head-Up Display



The **8-speed M Steptronic transmission with Drivelogic** features extremely short shifting times and numerous shifting options: from very athletic and dynamic to comfortable and fuel-efficient. The gears can also be shifted manually with the gear lever, or via gearshift paddles on the steering wheel.

¹ Available as optional equipment.

² Depending on conditions and usage, features specific to the materials used can lead to operational noises, particularly in wet conditions, just before the vehicle comes to a halt.

■ Standard equipment □ Optional equipment



Challenging the laws of physics is part of BMW M automobiles' DNA. This always includes a maximum amount of safety as well – because power is useless if it can't be controlled. This is why BMW M includes anticipatory technologies that support the driver to combine unlimited driving enjoyment with the highest degree of safety. A wealth of intelligent safety measures are in place to ensure that you always feel protected on the road, even when approaching the car's limits.

■ The **Adaptive LED headlights** include BMW Selective Beam, cornering lights and adaptive headlights. The light colour is similar to daylight and provides an ideal, even illumination of the road to improve visibility and make driving in the dark less tiring. The iconic light design with four light elements makes the vehicle recognisable as a BMW even at night.



■ The full-colour **BMW Head-Up Display with M specific functions¹** projects all information relevant for the journey directly into the driver's field of vision. With the press of a button, the driver can switch to the M specific display, which includes a gear indicator, the rpm as a dynamic range curve with shift lights indicating the optimal moment to shift as well as navigation tips.



□ The equipment package **Parking Assistant Plus** makes parking and manoeuvring the vehicle easier. It features Surround View including Top View, Remote 3D View, PDC as well as a lateral parking aid, the Active PDC emergency braking function and the Parking Assistant with linear guidance that provides fully automatic parking both parallel and perpendicular to the road.

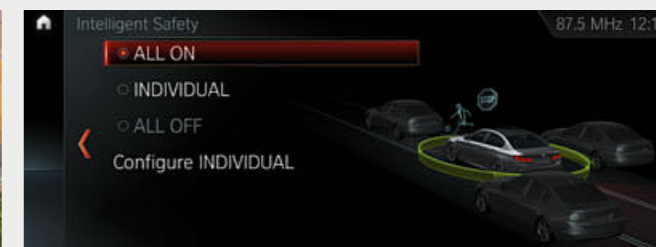

□ **Driving Assistant Plus³** offers greater comfort and security during monotonous or complex driving situations. These can include traffic jams, stop-and-go traffic or long journeys through the city, on country roads or motorways, along with navigating junctions and lane changes.



□ **BMW Night Vision with person recognition²** makes people and large animals visible on the Control Display from a distance using heat imaging and illuminates them with the Dynamic Marker Light in the main headlight. An additional warning system is also automatically activated when the vehicle is started, regardless of the status of the imaging display.

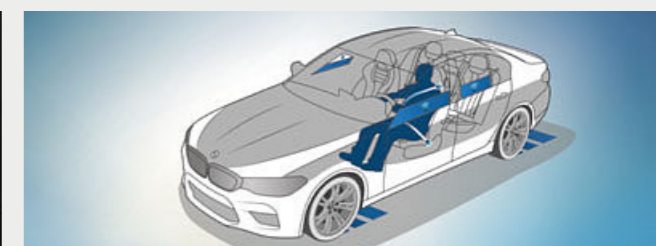

□ **Active Protection** is the BMW ConnectedDrive preventive passenger protection system. Active Protection warns the driver if it detects signs of tiredness, safety belts are pretensioned in critical situations, electric seats are returned to upright positions and the windows and sliding roof are closed. After an accident occurs, the brakes are automatically applied until the car reaches a standstill.

¹ The visuals in the BMW Head-Up Display are not fully visible when viewed through polarised sunglasses. Functionality shown is dependent on equipment. Further optional equipment is required for the display.

² Only available in conjunction with the Professional Navigation system.
³ This function can be limited by darkness and fog.

REGISTERS UP TO **360** DEGREES OF THE VEHICLE'S SURROUNDINGS.

Enjoy the ultimate in comfort and safety with the BMW Personal CoPilot. Whether it's for driving, parking or visibility, you can rely on BMW Personal CoPilot driver assistance systems in every situation. The most cutting-edge systems, such as radar, ultrasound and cameras, dependably register the vehicle's surroundings, forming the basis for intelligent driver assistance systems. Either activated when desired, or as emergency assistance in the background – BMW Personal CoPilot assistance systems make every journey in your BMW even safer and more enjoyable.

CONNECTED FOR OVER **40** YEARS.

Focused on the future – from the very beginning. By the 1970s, BMW had already made headway in connected mobility. Another milestone of the digital future was surpassed in 1999: vehicles with built-in SIM cards. Then came the first online functionality, Google Services and innovative display systems such as the BMW Head-Up Display. Throughout this process, the desires of the customer have always taken centre stage. In a first for a premium automobile manufacturer, BMW makes it possible to book and pay for services flexibly via the BMW ConnectedDrive Store, in the vehicle or on a computer at home. And with the introduction of BMW Connected and the Open Mobility Cloud, BMW is taking the next steps into the future of mobility.

MORE THAN **20** SERVICES AND APPS IN THE BMW CONNECTED DRIVE STORE.

The ConnectedDrive Services equipment forms the basis for intelligent BMW ConnectedDrive functions, as well as for the integration of selected smartphone apps. This equipment also provides access to the BMW ConnectedDrive Store, in which services and apps can be ordered and extended easily, any time and anywhere to suit the user's individual requirements – for example with the Concierge Service or Online Entertainment, which turn every drive into a convenient and entertaining experience.

IN TOUCH **24/7** WITH BMW CONNECTED.

What would it be like if you were never late again? What if your BMW already knew your preferred destinations? How would you like reliable navigation, whether you're sitting in your vehicle or not? BMW Connected provides you with the information you want, when and where you want it. BMW Connected is a personal mobility assistant which facilitates your everyday mobility and aids you in reaching your destinations relaxed and on time. With the BMW Connected app, mobility-relevant information such as recommendations for optimal departure times are available at any time via smartphone or smartwatch and can be seamlessly transmitted to the car.

SHARE MY RIDE IN REAL-TIME.

Safely share your arrival time and current position in a map view with family and friends by using "Share live trip status"¹. The recipient receives a link to a website that displays the destination and current location of the vehicle on a map.

DOOR-TO-DOOR NAVIGATION.

Getting to your appointments relaxed and on time is no problem thanks to the "Door-to-door navigation" function¹ in BMW Connected. On arrival, users can use their smartphone or a connected smartwatch to be guided from their parked car to their final destination by foot.

REAL TIME TRAFFIC INFORMATION.

Real Time Traffic Information (RTTI)^{2,3} collects current traffic information about motorways, main and country roads and the most important urban routes. It relays information about delays and dangers almost instantly. The best alternative routes are suggested accordingly. On-Street Parking Information is included, making the parking space search more efficient.

CONCIERGE SERVICE.

The Concierge Service^{1,3} connects the driver to a BMW Call Centre agent at the push of a button. The agent can locate a particular restaurant, the nearest cash dispenser or an emergency pharmacy and send the address details directly to the BMW navigation system.

¹ The Internet option is only available in conjunction with ConnectedDrive Services.

² This feature is only available in conjunction with ConnectedDrive Services and a navigation system.

³ Available as optional equipment.

BMW M5.

Discover more with the new BMW catalogue app. Now available for your smartphone and tablet.

■ Standard equipment □ Optional equipment



Distinctive air inlets, a large kidney grille with double slats and a carbon roof echoing the contours of the bonnet underscore the dynamic proportions of the new BMW M5 and provide an instant visual cue indicating the car's power.



The M-specific twin tailpipes and hallmark M gills hint at the powerful engine in the new BMW M5.



■ The cockpit features red contrasts such as the M1 and M2 buttons on the M leather steering wheel, the Start/Stop button and the gear selector, providing added motor racing appeal in the interior. The M pedal system with foot support and knee pads ensures superior vehicle control.



□ 20" M light alloy wheels
Double-spoke style 706 M Black, burnished, with mixed-size tyres, front 9.5J x 20 with 275/35 R20 tyres, rear 10.5J x 20 with 285/35 R20 tyres.



□ The optional M multifunction seats for the driver and front passenger combine the comfort of a saloon seat with the appearance and functionality of a bucket seat as used in motor racing. The semi-integrated headrest can be adjusted for height. The illuminated M5 badge in the headrest features an electroplated surround and high-end glass finish for an exclusive appearance.



BMW M5 FIRST EDITION.

This collector's item will go fast: the First Edition, limited to 400 vehicles worldwide, is an even more exclusive variant of the new BMW M5. The BMW Individual paint finish in Frozen Dark Red metallic highlights this sports car's powerful contours to maximum effect. Exclusive high-gloss Black elements such as the BMW kidney grille, the M gills or the high-gloss Black tailpipes make for distinctive contrasts. The 20" light alloy Double-spoke style 706 M wheels in Black further underscore the spectacular impression. In the interior, M multifunction seats with BMW Individual full-leather trim in fine-grain Merino leather with red contrast stitching provide sporting and elegant comfort. The exclusivity of this exceptional vehicle is emphasised by lettering on the Piano Finish Black centre console: the "M5 First Edition 1/400" wordmark reminds you every day that the car you own is one of a select few.



inspired by **BMW Individual**

The M multifunction sets with adjustable headrests come with BMW Individual full leather trim in fine-grain Merino leather, with the classic double felled seam in contrasting Red further underscoring the interior's sporting credentials.¹

¹ Includes leather-upholstered instrument panel, with the top in Black Walknappa leather with contrast stitching and the lower portion in fine-grain Merino leather matching the upholstery colour.



BMW INDIVIDUAL.

Express your personality.

The new BMW M5. Inspired by BMW Individual.

The BMW Individual Collection provides a sheer unlimited range of exclusive customisation options – for you to turn your vision into reality. All upgrades excel with the most sophisticated materials and high-end workmanship – BMW Individual represents perfection down to the most minute detail. The vehicle's elegantly dynamic character is enhanced as much by the BMW Individual paint finish in Frozen Arctic Grey metallic as by the full BMW Individual fine-grain Merino leather upholstery in Tartufo. The BMW Individual headliner in Alcantara Anthracite and the BMW Individual fine-wood interior trim in high-gloss Plum Brown – an absolute rarity – complete this expressive and prestigious ensemble.

For even greater distinctiveness and exclusivity, BMW Individual Manufaktur can also provide customers with hand-crafted, one-off items on request. This includes the BMW M5 First Edition in Frozen Dark Red metallic, which is limited to just 400 cars.



**EXPERIENCE BMW INDIVIDUAL INTERACTIVE.
WITH THE BMW INDIVIDUAL APP FOR iOS AND ANDROID.**



BMW Individual fine-wood interior trim in high-gloss Plum Brown. The wood veneer will change over time to bring out darker hues and entices the eye with an unusually rich interplay of colours.

BMW Individual full leather trim featuring fine-grain Merino leather in Tartufo.

EQUIPMENT HIGHLIGHTS.

Discover more with the new BMW catalogue app. Now available for your smartphone and tablet.

■ Standard equipment □ Optional equipment



■ BMW Individual high-gloss Shadow Line includes numerous equipment details in Black high-gloss: the side window frame trim strips, window recess finishers, B-pillars, window guides and mirror bases.



■ The M gills with model logo ensure optimal airflow around the wheel arches thanks to an integrated Air Breather. At the same time, the pronounced three-dimensional look underscores the M line's distinctive combination of technical perfection and breathtaking design.



□ The M Carbon ceramic brake¹ delivers braking power more directly. It is non-corrosive, very resistant to abrasion, tolerates more heat and contributes to a lower vehicle weight, which has a positive impact on agility, dynamics and acceleration. Matt Gold-coloured brake callipers with the M designation make this special technical equipment visible from outside the car.



■ The Adaptive LED headlights include BMW Selective Beam, cornering lights and adaptive headlights. The light colour is similar to daylight and provides an ideal, even illumination of the road to improve visibility and make driving in the dark less tiring. The iconic light design with four light elements makes the vehicle recognisable as a BMW even at night.



■ 19" M light alloy wheels Double-spoke style 705 M Orbit Grey with mixed-size tyres, burnished, front 9.5J x 19 with 275/40 R19 tyres, rear 10.5J x 19 with 285/40 R19 tyres.

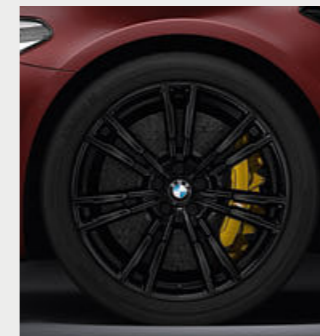

□ 20" M light alloy wheels Double-spoke style 706 M Black with mixed-size tyres, front 9.5J x 20 with 275/35 R20 tyres, rear 10.5J x 20 with 285/35 R20 tyres.



□ 20" M light alloy wheels Double-spoke style 706 M Black, burnished, with mixed-size tyres, front 9.5J x 20 with 275/35 R20 tyres, rear 10.5J x 20 with 285/35 R20 tyres.



□ Automatic tailgate operation allows the convenient opening and closing of the tailgate by simply pressing the button located in easy reach in the door panelling or on the car key. The tailgate can also be opened in the conventional manner, using the outside handle, and closed pressing a button on the inside of the tailgate.



□ The Comfort access system makes it possible to open all four vehicle doors, including the luggage compartment, without using the key. This equipment option includes contactless opening and closing of the tailgate² with a quick wave of the foot under the rear bumper.

¹ Due to the nature of the material and according to situation and use, the functioning of the M Carbon Ceramic brakes may be audible, particularly when wet shortly before the vehicle comes to a standstill.

² Contactless opening and closing of the tailgate only in combination with Automatic tailgate operation.

Optional and standard equipment vary according to country.

EQUIPMENT HIGHLIGHTS.

Discover more with the new BMW catalogue app. Now available for your smartphone and tablet.

■ Standard equipment □ Optional equipment



□ The M Multifunction seats for the driver and front passenger in exclusive design with illuminated M5 logo reflect the vehicle's athletic look. Lower seat bases and high side bolsters emphasize the shell-seat look and guarantee flawless lateral support. Accompanied by a comprehensive range of adjustment possibilities, maximum comfort is achieved.



■ The full-colour BMW Head-Up Display¹ with M specific functions projects all information relevant for the journey directly into the driver's field of vision. With the press of a button, the driver can switch to the M specific display, which includes a gear indicator, the rpm as a dynamic range curve with shift lights indicating the optimal moment to shift as well as navigation tips.



■ Dynamic and comfortable: The individually adjustable Sport seats for the driver and front passenger feature numerous electric adjustment options, including backrest width and seat height. Together with adjustable thigh support, the taller seat and backrest bolsters provide excellent ergonomics and more lateral support during fast cornering.



■ Ambient light creates a relaxed, cosy lighting atmosphere in the interior, and features vicinity illumination in the exterior door handles. There are eleven predefined light designs available in six different colours, with contour and ambient lighting on the instrument panel, door trim and centre console.



■ The M specific instrument cluster features five analogue displays – speedometer, rev counter, fuel gauge, oil temperature and fuel consumption – as well as a status indicator for the M Driving dynamics systems – steering, suspension, engine, Drivelogic and M xDrive. An Info Display shows the exterior temperature and on-board computer functions, for example.



■ Automatic air conditioning with two-zone control allows the driver and front passenger to set separate air volume and temperature preferences. Includes rear air vents, microfilter, active carbon filter, Automatic Air Recirculation (AAR), fogging sensor, "maximum cooling" and auxiliary ventilation function.



□ Exclusive ceramic applications on the volume and temperature controls for example lend a particularly high-quality look.



■ If the vehicle is fitted with the BMW Individual headliner anthracite, not only the headliner but also the trims on the roof pillars, sun visors and rear shelf are finished in Cloth anthracite.



□ The Automatic air conditioning with 4-zone control comes with the equipment included in Automatic air conditioning with 2-zone control with extended features, along with two air vents in the B columns. Additionally, the rear passengers can individually adjust their own climate via a separate control element with display.



■ The Double-spoke design M leather steering wheel includes multifunction buttons, the M emblem, chrome detailing, M1 and M2 buttons and an integrated driver-side airbag. Featuring a steering wheel rim in black leather with colour contrast stitching and contoured thumb rests, it feels great in the hand.

¹ The information in the BMW Head-Up Display is not fully visible when viewed through polarised sunglasses. The exact content shown will depend on the equipment options chosen. Further optional equipment is required for content to be displayed.

EQUIPMENT HIGHLIGHTS.

Discover more with the new BMW catalogue app. Now available for your smartphone and tablet.

■ Standard equipment □ Optional equipment



□ With BMW Gesture Control¹, certain functions can be operated by means of defined hand movements. For certain operations the system will for example recognise gestures such as 'swiping' or 'pointing' for accepting or rejecting an incoming call, or circular motions of the index finger to adjust volume.



□ The M Driver's Package increases the top speed to 305 km/h. The M Driver's Package can be ordered when purchasing a new vehicle or can be added on at a later date. All other technical data remain unchanged once installed. This also includes a voucher for BMW M Intensive Training as part of BMW Driving Experience.³



□ The Bowers & Wilkins Diamond surround sound system¹ with two diamond tweeters features outstanding studio-quality sound for every seat in the car. 16 carefully positioned speakers ensure a mesmerising sound experience. The speakers are illuminated, visually emphasizing the system's outstanding sound quality.



□ The outstanding Harman Kardon surround sound system¹ features a 600 W digital amplifier, 9 channels and 16 speakers. Its sophisticated sound perfectly fills the interior space. Vehicle-specific, speed-dependent equalising precisely compensates for any background driving noise.

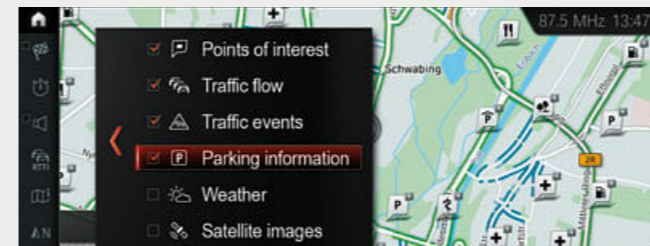

□ On-Street Parking Information simplifies the search for a parking space by searching for a free parking space in selected big cities. The streets on the navigation map are colour-coded to reflect the probability of a free space. Dark blue indicates a high probability and light blue a medium probability of finding a free parking space on the street.⁴



□ The Massage function for driver and passenger improves the physical wellbeing by stimulating or relaxing certain muscle groups. There are eight massage programmes dedicated to different parts of the body.⁵



■ The High-beam assistant supports driving in the dark by automatically adjusting the headlights in response to oncoming traffic or vehicles up ahead.



□ The BMW display key shows various information about the vehicle's status and allows selected functions to be controlled with an integrated touch display.



□ Telephony with wireless charging² includes a wireless charging dock and additional USB ports. A roof aerial connection improves mobile reception. Two mobile telephones and an audio player can be connected simultaneously via Bluetooth. Also included are: Bluetooth Office and the technical capacity for a WiFi hotspot.



□ Using the BMW M Laptimer app, driving data from the racetrack can be recorded accurately and then analysed. The recorded information can be shared as a snapshot on social media while the data, including accelerator position, steering angle, G-force and best lap time, can be sent by email. A GoPro interface is also incorporated.



□ With Remote 3D View, you can see your parked vehicle's surroundings from a distance on a smartphone. The function can be activated via the BMW Connected App (for iOS). It also enables you to save the 3D images on your smartphone.⁶

¹ Only available in conjunction with the Professional Navigation system.
² Supports inductive charging for Qi-compatible mobile phones. Special charging cases are available from Original BMW Accessories for selected smartphones that do not

support the Qi standard for inductive charging. The WiFi hotspot fulfils all in-vehicle requirements for use of the internet with the maximum LTE standard. Usage is subject to cost.

³ The raised top speed is only available after the first service following the 2,000 km run-in period.
⁴ On-Street Parking Information available only for selected models and markets. Only available in conjunction with Real Time Traffic Information. Only available in conjunction with ConnectedDrive Services and a navigation system.

⁵ Only available in conjunction with M multifunction seats.
⁶ Use of Remote 3D View requires Remote Services and Parking Assistant Plus.
Optional and standard equipment vary according to country.

EXTERIOR COLOURS.

Discover more with the new BMW catalogue app. Now available for your smartphone and tablet.

■ Standard equipment □ Optional equipment



■ **Non-metallic** 300 Alpine White



■ **Metallic** B41 Singapore Grey



■ **Metallic** C1K Marina Bay Blue



■ **Metallic** C1G Snapper Rocks Blue



■ **Metallic** 475 Black Sapphire

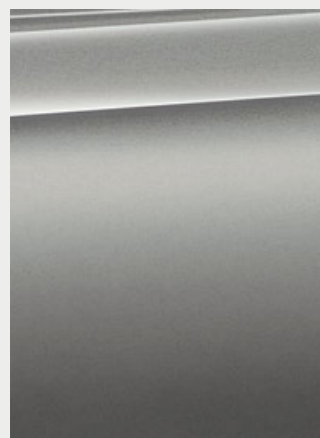

■ **Metallic** C28 Donington Grey

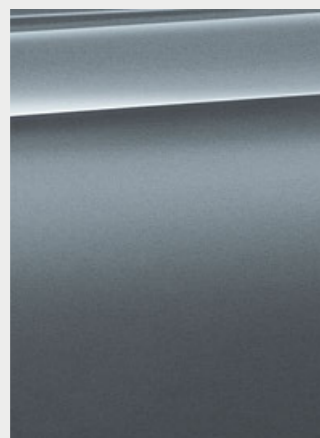

■ **Metallic** C2Y Bluestone

BMW M5 FIRST EDITION

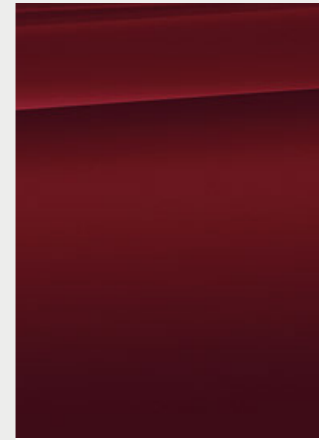

■ **BMW Individual** 490 Frozen Dark Red metallic



□ **BMW Individual** 490 Frozen Dark Silver metallic

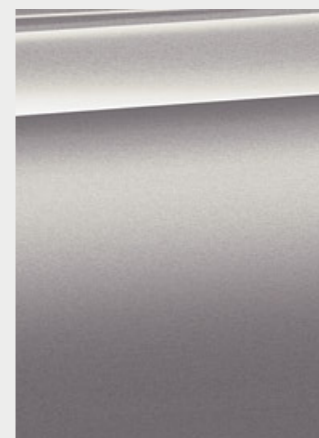

□ **BMW Individual** X17 Rhodonite Silver metallic

BMW INDIVIDUAL

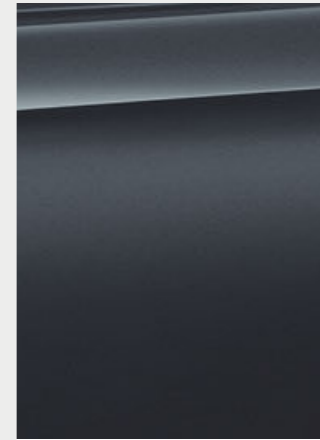

□ **BMW Individual** 490 Frozen Arctic Grey metallic



□ **BMW Individual** 490 Frozen Brilliant White metallic

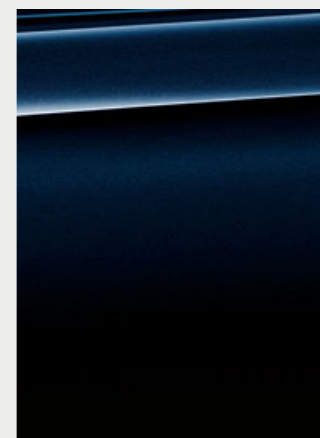

□ **BMW Individual** S34 Azurite Black metallic



□ **BMW Individual** 490 Frozen Dark Brown metallic

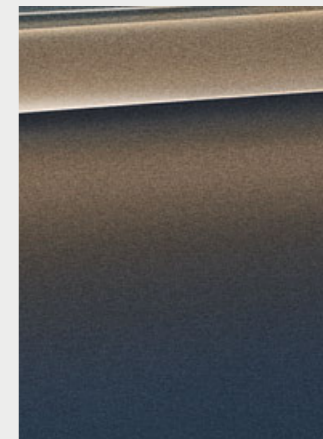

□ **BMW Individual** X08 Champagne Quartz metallic



□ **BMW Individual** 490 Brilliant White metallic



□ **BMW Individual** 490 Frozen Cashmere Silver metallic

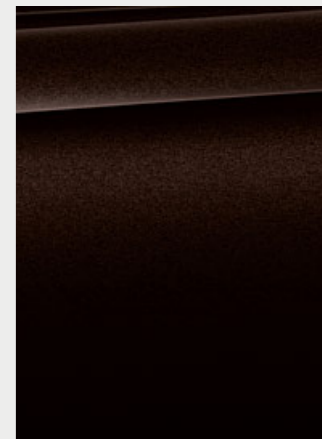

□ **BMW Individual** X14 Almandine Brown metallic



□ **BMW Individual** 490 Pure metal Silver

[Colour samples] These colour samples are intended as an initial guide to the colours and materials available for your BMW. However, experience has shown that printed versions of paint, upholstery and interior trim colours cannot in all cases faithfully reproduce the

appearance of the original colour. Please discuss your preferred colour choices with your BMW partner or dealership. There you can also see original samples and be assisted with special requests.

Optional and standard equipment vary according to country.

INTERIOR COLOURS.

Discover more with the new BMW catalogue app. Now available for your smartphone and tablet.

■ Standard equipment □ Optional equipment

LEATHER



■ **Extended fine-grain Merino leather** LKA9 Silverstone

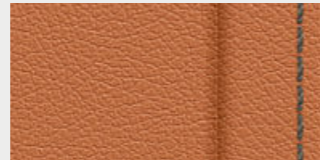

■ **Extended fine-grain Merino leather trim** LKD8 Aragon Brown

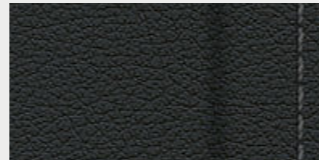

■ **Extended fine-grain Merino leather** LKSW Black



□ **Full fine-grain Merino leather** X3A9 Silverstone

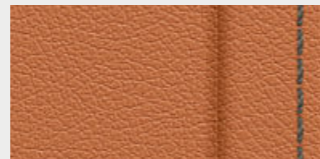

□ **Full fine-grain Merino leather trim** X3D8 Aragon Brown

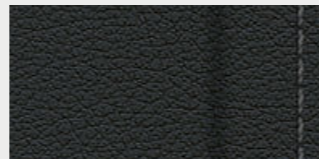

□ **Full fine-grain Merino leather** X3SW Black

BMW INDIVIDUAL



LEATHER

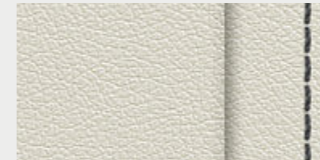

□ **BMW Individual full leather Merino fine grain** ZBFU Smoke White¹



□ **BMW Individual full leather Merino fine grain** ZBCR Caramel



□ **BMW Individual full fine-grain Merino leather** ZBTQ Tartufo

HEADLINER



■ **BMW Individual headliner** 775 Anthracite

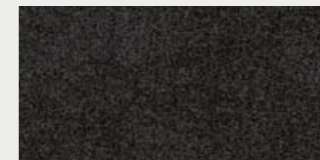

□ **BMW Individual headliner** 776 Alcantara Anthracite

INTERIOR TRIM



■ **4WN Aluminium Carbon Structure** interior trim with Pearl-Gloss Chrome accent line



□ **4WM Aluminium Carbon Structure** dark interior trim with Dark Chrome accent line

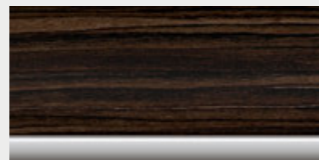

□ **4LF Fineline Ridge fine-wood trim** with Pearl-Gloss Chrome accent line

BMW INDIVIDUAL



INTERIOR TRIM

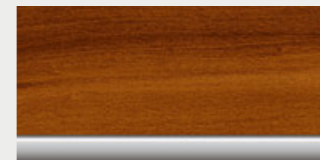

□ **BMW Individual interior trim finisher** 4WY Fine-wood trim Plum Brown high-gloss



□ **BMW Individual interior trim** 4ML Piano finish Black



□ **BMW Individual interior trim** XEW Fine-wood trim Sen Light Brown

Please note that even normal long or short-term use can lead to permanent upholstery damage. This can be caused in particular by non-colourfast clothing.

¹ Exclusively available in conjunction with BMW M5 First Edition.

Optional and standard equipment vary according to country.

BMW M5

Weight

Unladen EU ¹	kg	1930
Max. permissible	kg	2440
Permitted load	kg	585
Permitted trailer load, unbraked ²	kg	750
Permitted trailer load, braked, max. 12% gradient/max. 8% gradient ²	kg	2000/2000
Luggage compartment capacity	l	530

Engine

Cylinders/valves		8/4
Capacity	cc	4395
Rated output/rated engine speed	kW (hp)/ rpm	441 (600)/ 5600–6700
Max. torque/engine speed	Nm/rpm	750/1800–5600

Power transmission

Drive configuration	All-wheel
Standard transmission	8-speed M Steptronic

Performance

Top speed	km/h	250 ^{3,6}
Acceleration 0–100 km/h	s	3.4
Acceleration 0–200 km/h	s	11.1

Fuel consumption^{4,5}

Urban	l/100 km	14.5
Extra-urban	l/100 km	8.2
Combined	l/100 km	10.5
CO ₂ emissions, combined	g/km	241
Tank capacity (approx.)	l	68

Wheels/tyres

Tyre dimensions	Front: 275/40 ZR 19 Rear: 285/40 ZR 19
Wheel dimensions	9.5J x 19 / 10.5J x 19
Material	Light alloy

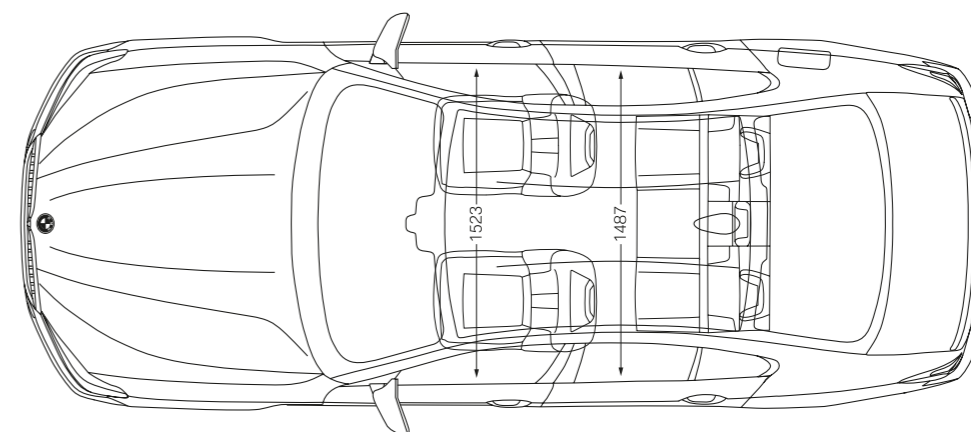
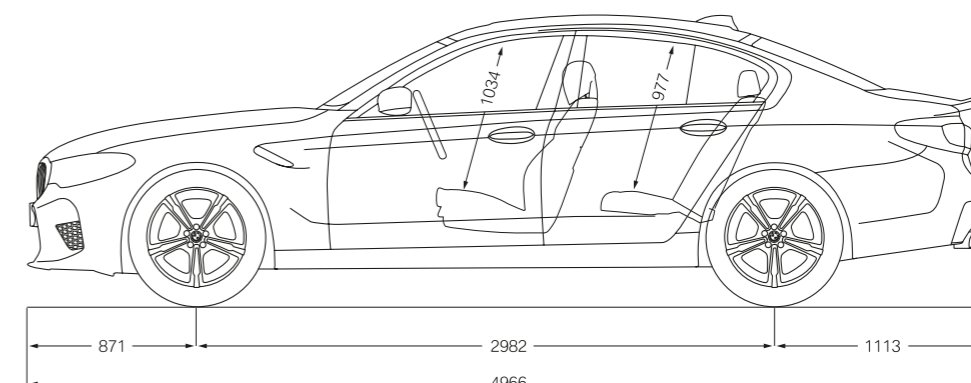
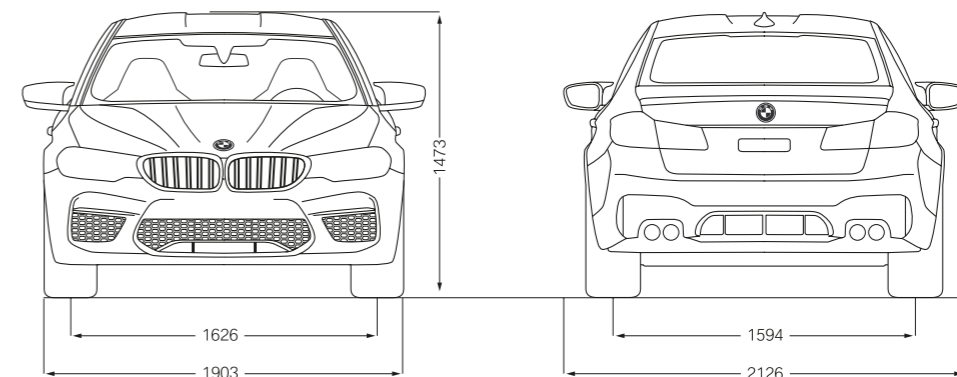

All dimensions in the technical drawing are given in millimetres.

¹ Figures quoted are based on a 90% full tank and a driver weight of 75 kg. Unladen weight applies to vehicles with standard equipment. Optional equipment may increase vehicle mass.

² The actual total weight of the trailer must not exceed the maximum permitted trailer load, taking into account the maximum tow bar download.

³ Electronically restricted.

⁴ BMW recommends the use of RON 95 super unleaded petrol. Unleaded RON 91 and higher with a maximum ethanol content of 10% (E10) may also be used. Performance and fuel consumption data refer to vehicles using RON 98 or diesel fuel.

⁵ The fuel consumption and CO₂ emissions figures shown were determined in accordance with the measurement process as defined by European Regulation (EC) 715/2007 in the version applicable at the time of type approval. Data refer to a vehicle with base-level equipment for the German market, and the ranges account for differences according to the selected wheel and tyre size and any optional equipment.

⁶ The M Driver's Package increases top speed to 305 km/h.

BMW M5:

M TwinPower Turbo 8-cylinder petrol engine, 441 kW (600 hp), 20" M light alloy wheels Double-spoke style 706 M Black, burnished, with mixed-size tyres, Marina Bay Blue metallic exterior colour, M multifunction seats for driver and front passenger with full-leather trim in BMW Individual fine-grain Merino leather in Silverstone/Black, Aluminium Carbon Structure dark interior trim with Dark Chrome accent line.

BMW M5 First Edition:

M TwinPower Turbo 8-cylinder petrol engine, 441 kW (600 hp), 20" M light alloy wheels Double-spoke style 706 M Black with mixed-size tyres, BMW Individual Frozen Dark Red metallic exterior colour, M multifunction seats for driver and front passenger with full BMW Individual fine-grain Merino leather upholstery in Smokey White with Red contrast stitching, BMW Individual Piano Finish Black interior trim.

The models illustrated in this brochure show the equipment and configuration options (standard and optional) for vehicles produced by BMW AG for the German market. Alterations in standard and optional equipment and the configurations available for the different models, as described in this brochure, may occur after 12.10.2017, the date when this brochure went to press, or according to the specific requirements of other markets. Your local BMW Partner is available to provide further details. Subject to change in design and equipment.

© BMW AG, Munich, Germany. Reproduction, even in part, only with the written approval of BMW AG, Munich.

4 11 005 339 20 2 2017 BM. Printed in Germany 2017.

